

Technical data



Pellematic® PES(K)(B) 10 - 56

ENGLISH



Author

ÖkoFEN Forschungs- &
EntwicklungsgesmbH
A-4133 Niederkappel, Gewerbepark 1
Tel.: +43 (0) 72 86 / 74 50
Fax.: +43 (0) 72 86 / 74 50 - 210
E-Mail: oekofen@pelletsheizung.at
www.oekofen.com

© by ÖkoFEN Forschungs- und EntwicklungsgesmbH
Subject to modifications

1 Technical data

Information according to EU regulation 2015/1187 and 2015/1189

Model designation	Pellematic								
	10	12	15	20	25	32	36	48	56
Manufacturer and contact details	ÖkoFEN Forschungs- und Entwicklungs GmbH, Gewerbepark 1, 4133 Niederkappel, Austria								
Boiler class	5								
Heat-up mode	Automatically								
Condensing boiler	no								
Solid fuel boiler with cogeneration system	no								
Combined heater	no								
Energy efficiency class	A+								
Energy efficiency index (EEI)	118	118	118	119	119	122	123	123	123
seasonal space heating energy efficiency in active mode η_{son}	85	85	84	85	86	87	87	87	87
Seasonal space heating energy efficiency η_s (based on upper heating value)	79	80	80	81	82	83	83	84	84
Delivered useful heat at nominal heat power P_n [kW]	10	12	15	20	25	32	36	48	56
Delivered useful heat at 30 % of the nominal heat power P_p [kW]	3	3	5	6	8	10	11	15	17
Boiler eff. rated power standard heat. mode [%]*	92,4	92,7	93	94	94,6	95,5	95,5	95,5	95,4

Fuel	Pellets made of 100% natural wood according to EN ISO 17225-2, class A1
Colorific value [kWh/kg]	4,6 - 5,3
Bulk density [kg/m ³]	≥ 600
Water content [Gew.%]	≤ 10
Ash parts [Gew.%]	≤ 0,7
Length [mm]	≤ 40
Diameter [mm]	6 ±1

Model designation	Pellematic								
	10	12	15	20	25	32	36	48	56
Annual space heating emissions									
PM [mg/m ³]	< 40								
OGC [mg/m ³]	< 20								
CO [mg/m ³]	< 500								
NOx [mg/m ³]	< 200								

Auxiliary power consumption									
Auxiliary power consumption at nominal heat power $e_{l_{max}}$ [W]	120								
Auxiliary power consumption at 30 % of nominal heat power $e_{l_{min}}$ [W]	36								
Standby auxiliary power consumption P_{SB} [W]	7								

Water area									
Water capacity [l]	64	64	64	64	104	104	135	135	135
Feed / return connection [inch]	1	1	1	1	5/4	5/4	2	2	2
Feed / return connection \varnothing [DN]	25	25	25	25	32	32	50	50	50
Water resistance at 10K [mbar]	54,7	95,2	150	220	284	376	38,9	51,9	60,5
Water resistance at 20K [mbar]	14,0	24,2	38,0	55,0	72	95,0	10,4	13,9	16,2
Boiler temperature [°C]	65 - 90								
Minimum boiler temperature [°C]	55								
Operating pressure maximum [Bar]	3								
Test pressure [Bar]	4,6								

Model designation	Pellematic								
	10	12	15	20	25	32	36	48	56
Flue gas area (Flue gas = F.g.)									
Combustion chamber temperature [°C]	500 - 870								
Need of draught rated power [mBar]	0,08								
Flue gas temperature partial load [mBar]	0,03								
Flue gas temp. rated power [°C]	160								
Flue gas temp. partial load [°C]	100								
F.g. volume rated power at f.g.tem. [kg/h]	20,3	24,2	30,4	39,2	48,0	66,5	73,1	92,9	119,3
F.g. volume partial load at f.g. tem. [kg/h]	6,4	7,9	10,3	14,6	19,0	28,1	31	39,8	45,6
F.g. volume rated power at AGT [m ³ /h]	21,9	28,9	37,6	50,2	63,2	51,2	56,3	71,5	81,7
F.g. volume partial load at AGT [m ³ /h]	5,8	6,9	10,9	13,0	17,4	21,6	23,9	30,6	35,1
Flue gas tube diameter (at the boiler) [mm]	130	130	130	130	150	150	180	180	180
Chimney diameter	as per chimney calculation								
Chimney construction	Steel or ceramic lined, damp resistant								

Model designation	Pellematic								
	10	12	15	20	25	32	36	48	56
Chimney calculation									
Rated heating power [kW]	10	12	15	20	25	32	36	48	56
Firing thermal capacity nominal load [kW]	11	13	16	22	27	35	39	52	60
CO ₂ volume concentration nominal load [%]	12,9	13	13,2	13,6	13,2	13	14,4	15,4	16
Flue gas inertia current for chimney calculation nominal load [kg/s]	0,00 56	0,00 67	0,00 84	0,010 9	0,013 3	0,018 5	0,02 03	0,02 58	0,02 95
Flue gas temperature for chimney calculation nominal load [° C]	120	120	160	160	160	160	160	160	160
Required (+) or maximum (-) delivery pressure nominal load [Pa]	8	8	8	8	8	8	8	8	8
Rated heating power partial load [kW]	3	3,4	5	6	8	10	11	15	17
Rated thermal power partial load [kW]	3,2	3,69	5,2	6,59	8,78	11,0	12,1	16,5	18,7
CO ₂ volume concentration partial load [%]	10,1	9,6	8,6	10,5	10,6	10,7	10,5	10,7	10,8
Flue gas inertia current for chimney calculation partial load [kg/s]	0,001 4	0,001 7	0,00 22	0,00 31	0,00 41	0,00 60	0,00 66	0,00 85	0,00 98
Flue gas temperature for chimney calculation partial load [° C]	80	80	100	100	100	100	100	100	100
Required (+) or maximum (-) delivery pressure partial load [Pa]	3	3	3	3	3	3	3	3	3

Weight			
Weight of boiler packaged on pallet with wooden frame [kg]	385		650
Overall Weight [kg]	350		605
Boiler Body Weight [kg]	240		422
Internal ash pan volume [kg]	25		30
Ash capacity ash box [kg]	25		

Model designation	Pellematic								
	10	12	15	20	25	32	36	48	56
Electrical Components									
Connection value	230 VAC, 50Hz, 16A								
Main Drive [W]	40								
Drive Motor [W]	250 / 370								
Vacuum turbine [W]	1400								
Combustion Air Blower [W]	62						83		
Flue gas fan [W]	25						32		
Electrical Ignition - [W]	250								
Cleaning Motor [W]	40								
Motor External Ash Box [W]	40								
Motor Burner plate cleaning system [W]	40								
Flame Return Gate [W]	5								
Protection class	IP20								

* Test bench value related to the lower calorific value of the fuel. Determined at continuous full-load ideal operation according to the measurement procedures in EN303-5. Practical values and seasonal efficiencies may deviate due to local conditions, fuel properties and individual modes of operation. The values do not refer to an individual boiler, but serve solely for comparison purposes between the different boiler types.



Further technical data and results of the type test available on request from your ÖkoFEN contact.

2 Notes on bringing the unit into the building

Before bringing the unit into the building, check the dimensions of all doors to ensure that the boiler has sufficient clearance and can be set up properly.

Minimum door width		
PES, PESK	10, 12, 15, 20 kW	690 mm
PES, PESK	25, 32 kW	750 mm
PES	36, 48, 56 kW	800 mm

Boiler dimensions

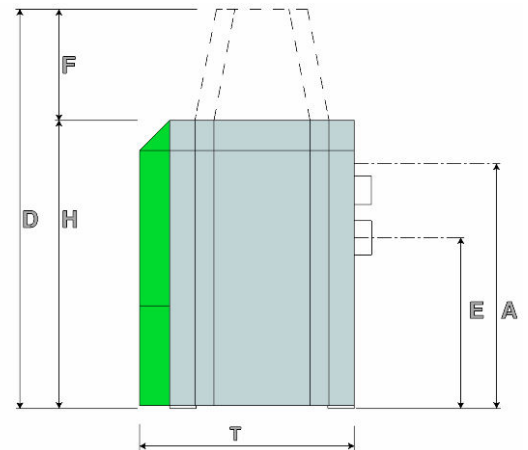
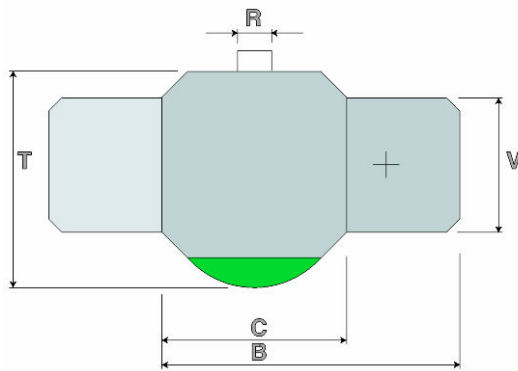

Boiler size in mm	PES 10	PES 12	PES 15	PES 20	PES 25	PES 32	PES 36	PES 48	PES 56
B: overall width of pellet boiler	1130	1130	1130	1130	1186	1186	1297	1297	1297
C: width of boiler casing	700	700	700	700	756	756	862	862	862
H: height of boiler casing	1090	1090	1090	1090	1290	1290	1553	1553	1553
D: height of pellet suction system	1392	1392	1392	1392	1592	1592	1855	1855	1855
F: height of suction system filling unite	302	302	302	302	302	302	302	302	302
T: depth of boiler casing	814	814	814	814	870	870	990	990	990
V: depth of burner casing	508	508	508	508	508	508	508	508	508
E: height of flue gas tube connection	645	645	645	645	844	844	1040	1040	1040
A: height of inlet/return	905	905	905	905	1110	1110	1320	1320	1320
R: diameter of flue gas tube	130	130	130	130	150	150	180	180	180

Boiler Weight

Weight in kg	PES 10	PES 12	PES 15	PES 20	PES 25	PES 32	PES 36	PES 48	PES 56
Weight of boiler packaged on pallet with wooden frame	385	385	385	385	470	470	650	650	650
Weight of boiler with casing, hopper and burner	350	350	350	350	430	430	605	605	605
Weight of boiler without casing, hopper and burner	230	230	230	230	300	300	422	422	422

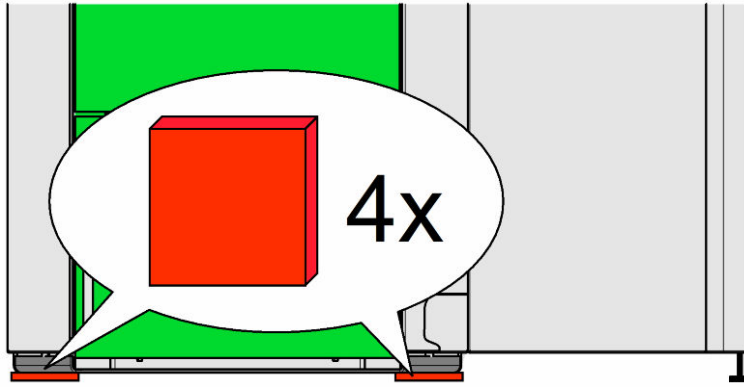
Placement of rubber plates**NOTICE**

The pellet heating boiler must be placed on the supplied rubber plates.

Minimum clearance dimensions required



To install the heating system properly and ensure economical operation, you need to make sure that minimum clearance dimensions indicated below are observed when setting up the boiler.

In addition, make sure that legislation in your country is complied with relating to the minimum clearance of the flue gas tube.

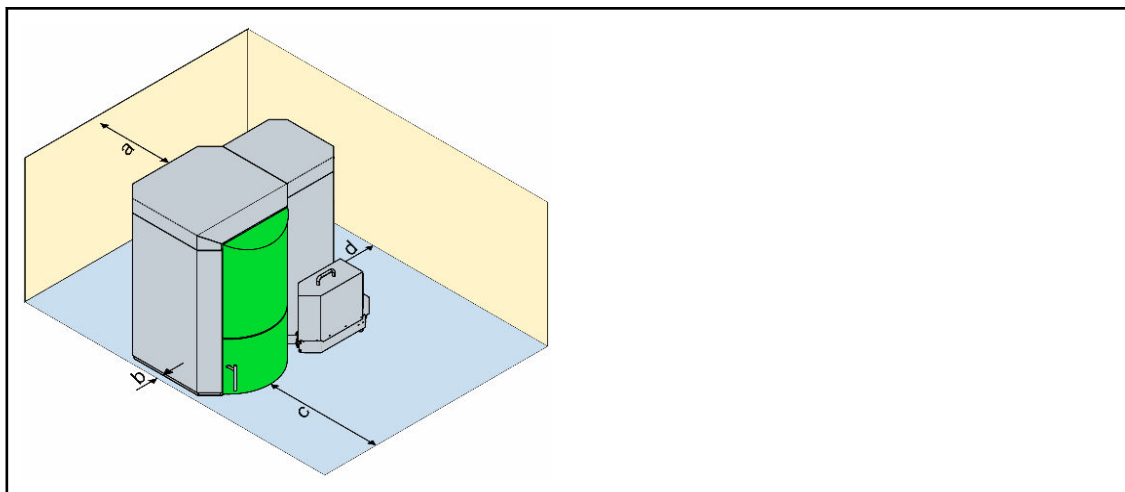

a	Min. clearance of flue gas connection from wall or part of building	450 mm
b	Min. clearance of side of boiler from wall or part of building	50 mm
c	Min. clearance of front of boiler from wall or part of building	700 mm
d	Min. clearance of side of burner from wall or part of building	300 mm

Before bringing the unit into the building, check the dimensions of all doors to ensure that the boiler has sufficient clearance and can be set up properly.

Minimum door width – max. unit dimension		
PES, PESK	10, 12, 15, 20 kW	750 mm
PES, PESK	25, 32 kW	800 mm
PES	36, 48, 56 kW	800 mm

Boiler dimensions

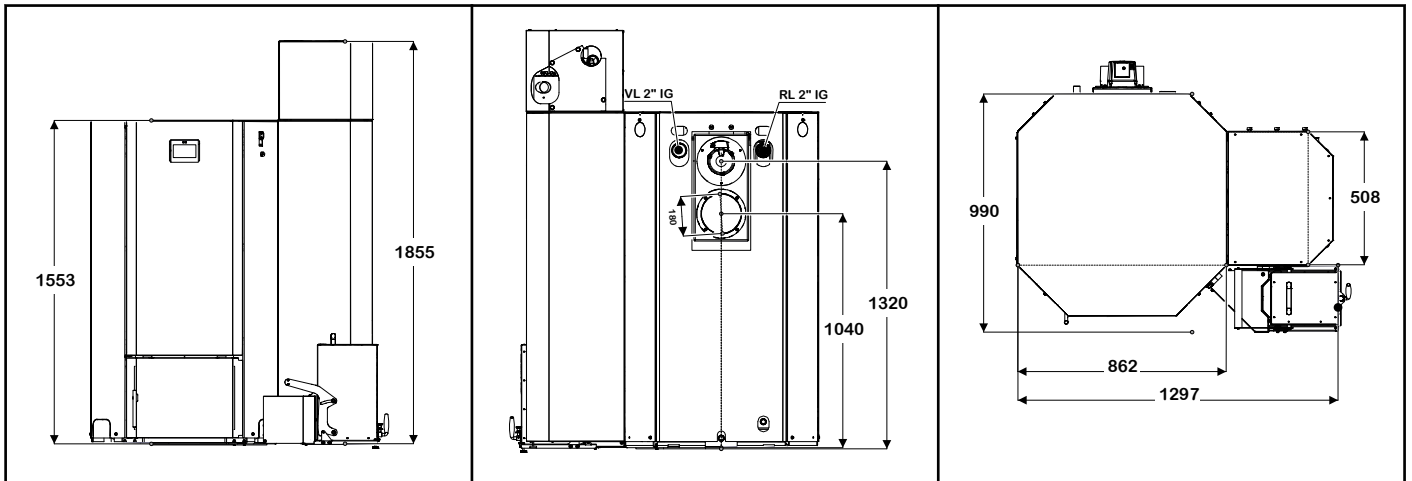

Boiler Weight

Weight in kg	PES 10	PES 12	PES 15	PES 20	PES 25	PES 32	PES 36	PES 48	PES 56
Weight of boiler packaged on pallet with wooden frame	385	385	385	385	470	470	650	650	650
Weight of boiler with casing, hopper and burner	350	350	350	350	430	430	605	605	605
Weight of boiler without casing, hopper and burner	230	230	230	230	300	300	422	422	422

Placement of rubber plates

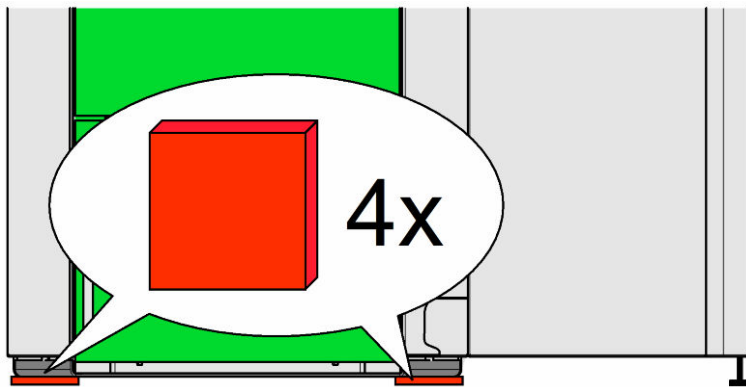

NOTICE

The pellet heating boiler must be placed on the supplied rubber plates.

Minimum clearance dimensions required



To install the heating system properly and ensure economical operation, you need to make sure that minimum clearance dimensions indicated below are observed when setting up the boiler.

In addition, make sure that legislation in your country is complied with relating to the minimum clearance of the flue gas tube.

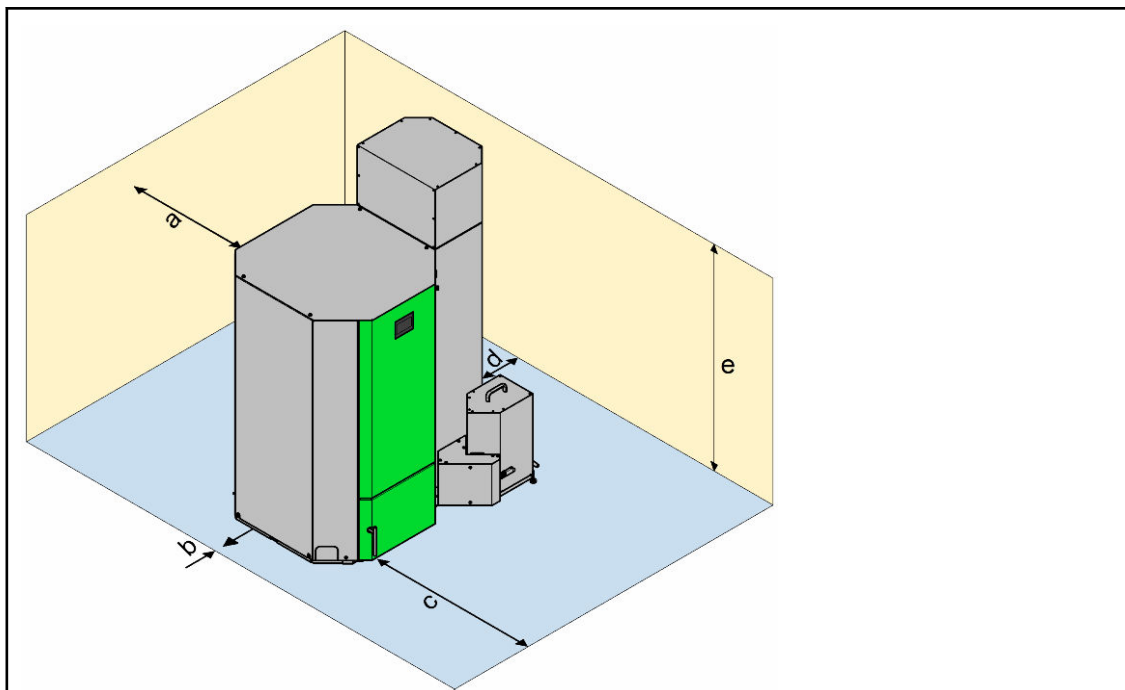

a	Min. clearance of flue gas connection from wall or part of building	450 mm
b	Min. clearance of side of boiler from wall or part of building	50 mm
c	Min. clearance of front of boiler from wall or part of building	700 mm
d	Min. clearance of side of burner from wall or part of building	300 mm
e	Min. room height	2000 mm



The indicated values must not fall below by piping or other.

NOTICE

Due to a low boiler surface temperature, the specified minimum distances can be observed.

- Legislation in your country must be observed!

ÖkoFEN